

屋外側

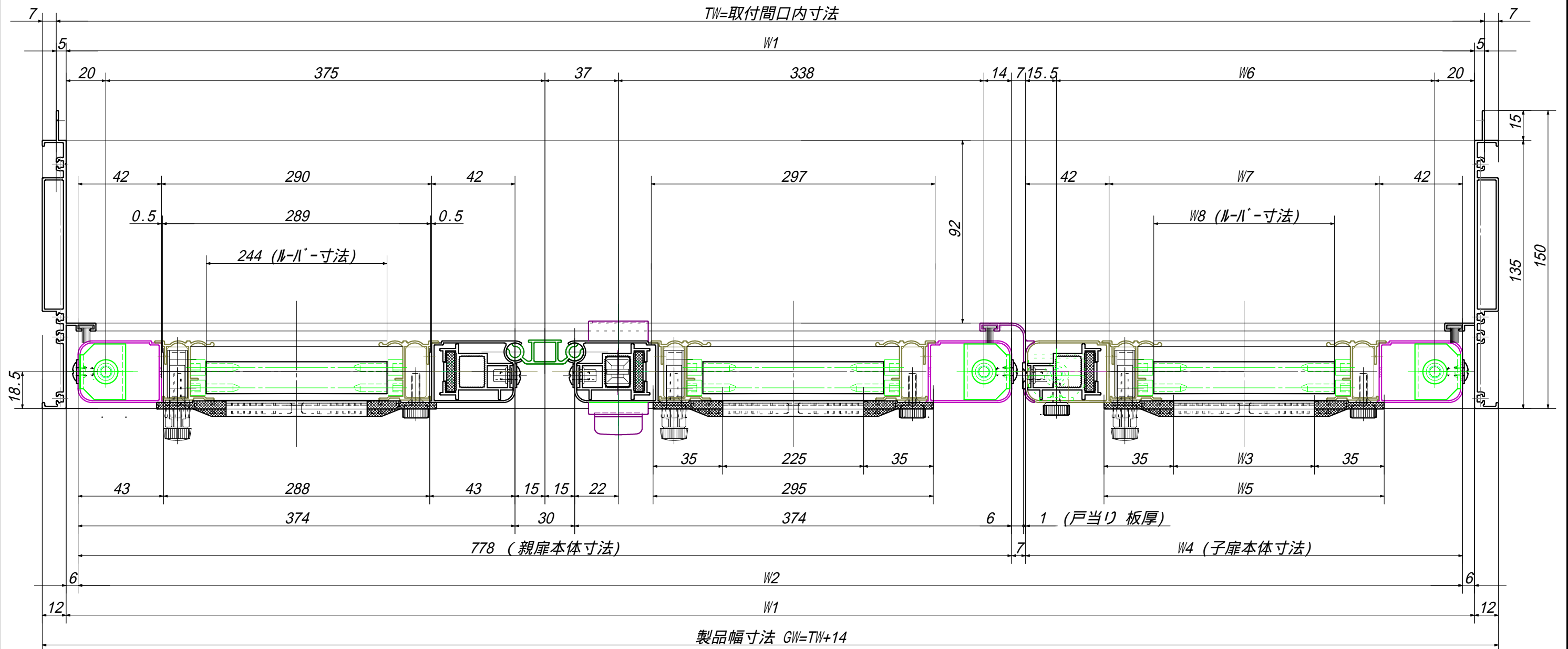

屋内側

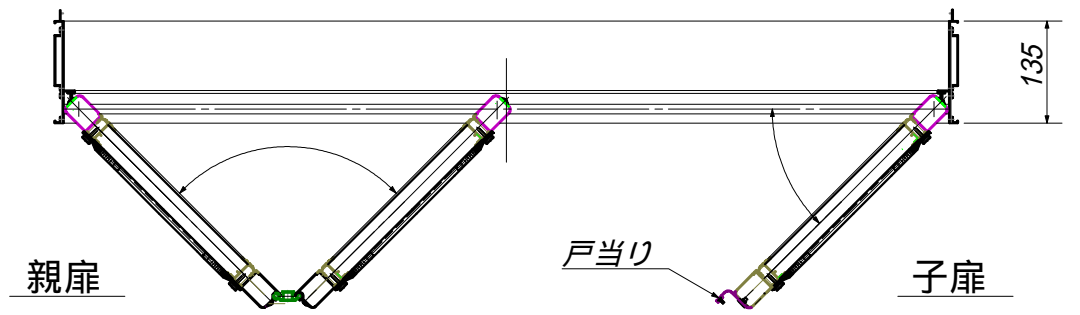

	GW	W 1	W 2	W 3
公式	TW-14	TW-10	TW-22	TW-(親扉幅寸法+178)
	W 4	W 5	W 6	W 7
	TW-(親扉幅寸法+29)	TW-(親扉幅寸法+108)	TW-(親扉幅寸法+58.5)	TW-(親扉幅寸法+113)
				TW-(親扉幅寸法+159)

HEAT TREATMENT		SURFACE FINISHING		PART NAME Nice Wind's Door	
SCALE 0:0		MATERIAL		親子扉詳細 親扉 W800 子扉(右)	
1:2 Free				PART NUMBER	
DRAWN BY		DESIGNED BY		IZK - 3551A01RA	
		YAMACHAN		JAC OSAKA CO, LTD JAPAN ALUMINUM CONTAINER	
		08,04,11			